

TOMCAT

MADE IN U.S.A.

XR Series

Rider Scrubbers



FAMILY OF COMMERCIAL CLEANING EQUIPMENT (17"-46")

SCRUBBERS



RIDERS



BURNISHERS



RIDER/BURNISHER



TOMCAT XR SCRUBBERS

These rugged and high performance scrubbers offer the productivity of the industry's largest equipment, but in a more maneuverable package.

With two specialized cleaning systems and five deck sizes to choose from, **TOMCATS** offer the results and capacity required to clean your unique application.

The "Disk" XRs offer gimballed brush drive and 45% more scrubbing power than competitive brands. The "Cylindrical" units reduce or eliminate dust mopping, by sweeping and scrubbing in a single pass.

The scrub decks include adjustable wipers and curtains, for unmatched water control. All components are made of heavy gauge steel for durability and accessibility is designed in to simplify service work.

PRODUCTIVITY

Productivity is a function of scrub path, run time and tank capacity, and **TOMCATS** top the chart.

1. Larger Tanks (68 gallons) = *Less stopping to refill*
2. Wider Scrub Path (46") = *Fewer trips down the aisle*
3. High Down Pressure = *Less double scrubbing*
4. Twin Vacuum Motors = *Dry, safe, clean floors*
5. Big Battery = *Runs a full shift*

EASY TO SERVICE

Any manufacturer can claim to build equipment that is both tough and easy to clean up, but we actually do and invite you to compare other equipment. Your maintenance staff will notice the difference immediately.

Tank Tips

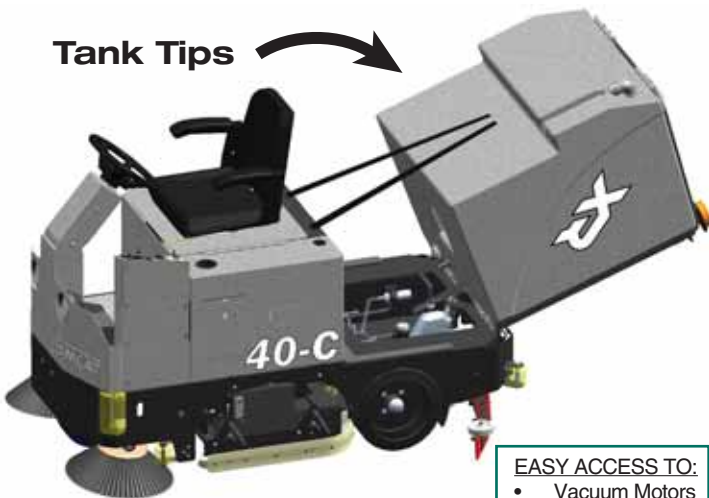

EASY ACCESS TO:

- Vacuum Motors
- Filters / Pump
- Valves
- Actuators

FREE DEMO (800) 634-4060



Safe on Tile Floors & Excellent Visibility

MAINTENANCE SCREEN

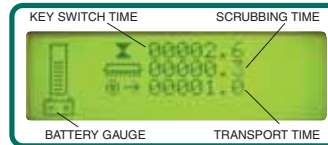

Large Lid
Complete Access to Clean

OPERATING SCREEN

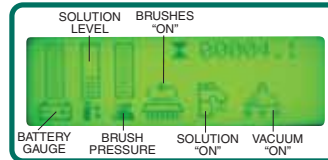

Large Tanks (68 gallons)
Increased Productivity

Massive Steel Frame
Durability in HD Applications

Non-Marking Tires Available
Optimum Stability
& Protection

Oversized Motors
Superior Cleaning & Long Lasting

Disk Decks
Excellent VCT
Performance

HD Roll
Protect

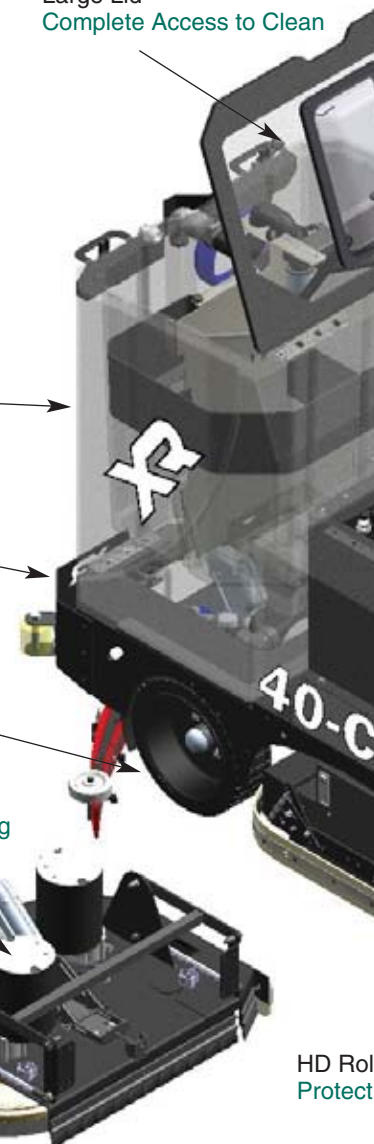

AVAILABLE OPTIONS

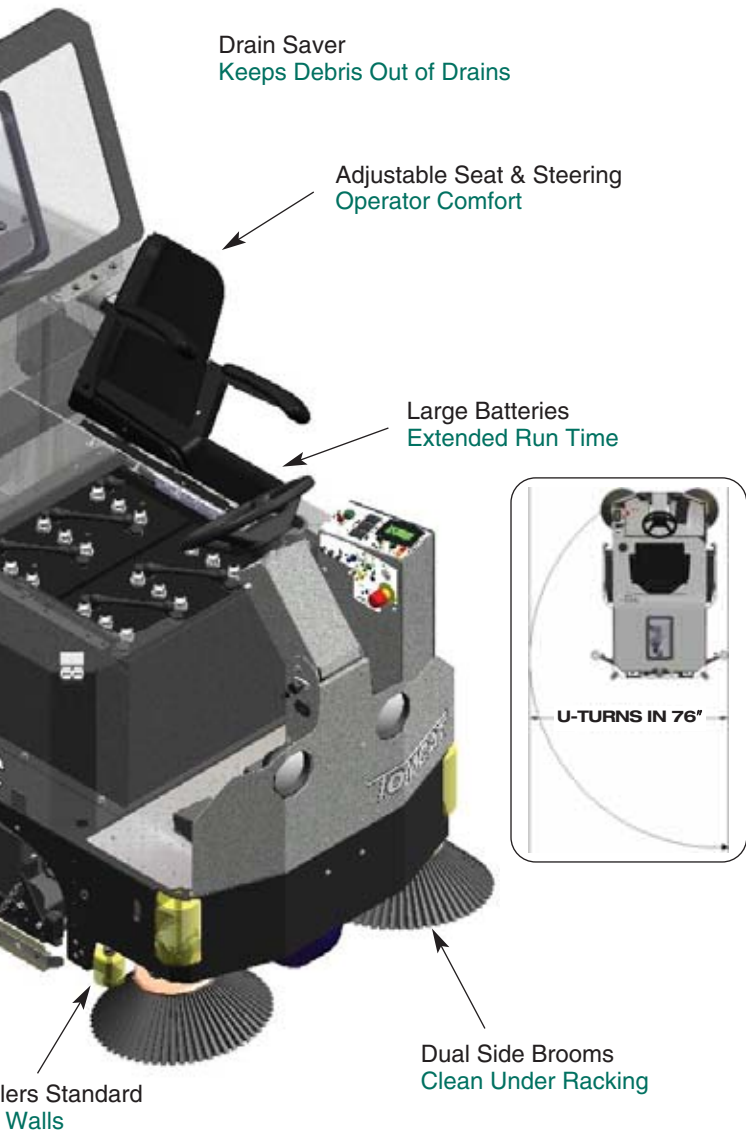
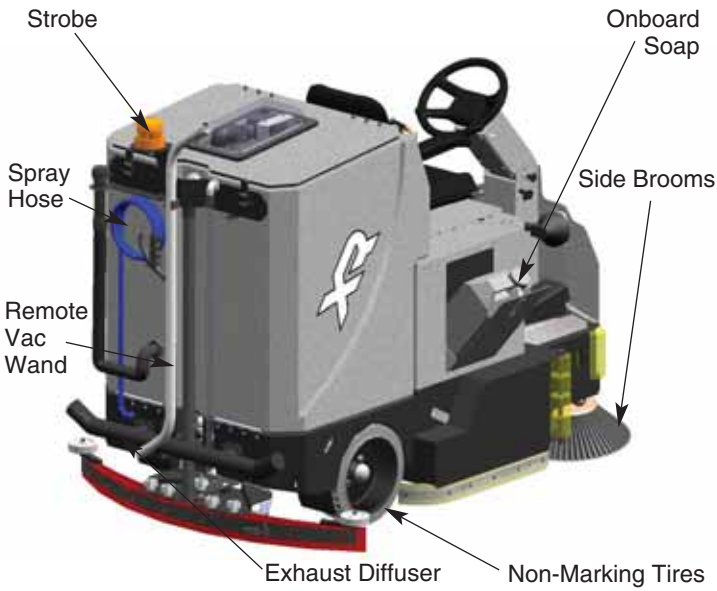

OPERATOR EASE

The operator sits in a spring-suspension, fully adjustable, mid-back chair. The adjustable steering column, armrests, and front guard further enhance operator comfort and safety. With a powerful drive motor, these machines can climb steep ramps, and come standard with heavy duty tires. Features include an automatic parking brake, and reduction of transport speed while scrubbing or backing up.

Our Central Command II system includes an LCD readout, on-board diagnostics, and three hour meters, simplifying preventive maintenance intervals. When the batteries discharge, the machine automatically shuts down all systems except "transport" to allow you to return to the charge station or any standard 20A outlet with the optional onboard charger.

BUILT TOUGH

TOMCATS use powerful motors, which typically run at only 50% of their capacity. This leaves power in reserve for times where heavy scrubbing is required, and prolongs motor life.

- Constructed of thick steel, and powder-painted to prevent corrosion.
- Tanks have extra-thick walls and brass inserts for strength.
- Tall polyurethane rollers disperse collision forces without leaving marks on your walls.
- **TOMCATS** use only stainless fasteners.



At Home in Tough Applications

EXPERIENCED DISTRIBUTORS

TOMCAT continues to grow by providing the toughest machines in our industry, at a reasonable investment. Our 300 distributors each maintain a factory-trained service department and diverse rental fleet, which allow them to continue serving your needs.

We offer a line of cleaning equipment that includes sweepers, burnishers and scrubbers in both walk-behind and rider models. Our machines are practical, rugged and sensibly priced. We can happily provide leasing information to those customers who prefer it.

Quality chemicals are a vital component to any cleaning program, so feel free to contact us with questions about "Approved" chemicals for use in our equipment.

GUARANTEED SERVICE

We guarantee to supply you the spare parts you need within three workdays, or they are yours free. This applies only to the 48 contiguous states, at the customer's special request, and to parts that can be shipped by courier.

AUTHORIZED DISTRIBUTOR

Manufactured By:
R.P.S. Corporation
P.O. Box 241 • Racine, WI 53401; USA
Phone: (800) 450-9824
Fax: (866) 632-6961
www.tomcatequip.com

Copyright R.P.S. Corporation 2007. All rights reserved. Since our policy is one of constant improvement, all specifications are subject to change without notice.

Body Construction/Dimensions

Tank Material:	Poly (3/8" thick)
Frame Construction:	7-gauge (3/16" Steel)
Rear Wheels (diameter x width):	14" x 5"
Drive Wheel (diameter x width):	12" x 4"
Size (L x W x H):	69" x 36" x 56"
Weight:	1,230 pounds
Weight (w / batteries):	1,950 pounds

Brush/Pad System

Brush Down Pressure:	0-350 pounds
Brush Pressure Settings:	(5) w / auto adjust

DISK

Brush / Pad Size:	370-34D: (2) 17"
	370-40D: (2) 20"

Brush Speed:	270-rpm
Motor Power:	(2) 1.5 hp

CYLINDRICAL

Brush Size:	370-34C: (2) 32" x 7"
	370-40C: (2) 38" x 7"
	370-46C: (2) 44" x 7"

Brush Speed	750-rpm
Motor Power:	(2) 1.5 hp

Battery System

Battery AH Rating (standard):	(Qty 6) 325 AH
Battery AH Rating (optional):	(Qty 6) 395 AH
Battery AH Rating (industrial Battery):	(Qty 1) 440 AH / 1,245 lbs.
Battery Run Time	Up to 6 hours
Charger (110-v / 60 hz, auto):	36-v / 36-amp

Solution System

Solution Tank Capacity:	68-gallons
Solution Flow Rate:	0-1.5 gpm
Solution Filter:	Inline Stainless

Recovery System

Recovery Tank Capacity:	68-gallons
Vacuum Power	1.6 hp
Vacuum (lift / airflow)	68" / 140 cfm
Demisting Chamber:	2.5 gallons

Drive System

Power:	3.0 hp, sealed
Type:	All Gear
Speed Control:	0-5 mph

General

Sound Levels:	71 dBA
Side Boom Path:	45"
Cleaning Width / Productivity:	370-34: 34"/36,720 sq. ft./hr.
	370-40: 40"/43,200 sq. ft./hr.
	370-46: 46"/49,680 sq. ft./hr.

Optional Equipment

- Maintenance Free Batteries
- Spray Hose
- Vacuum Wand
- Side Brooms
- Industrial Battery (440 ah)
- 85 Gallon Stainless Tanks
- Onboard Soap
- Onboard Charger
- Non- Marking Tires
- HD Package (Side Doors)
- Overhead Guard
- Variety of Brushes and Squeegees