

XR SERIES

XR Scrubber
Specifications

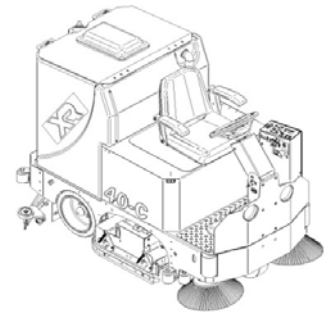

Disc

Cylindrical

BODY CONSTRUCTION / DIMENSIONS:

Tank Material:	Poly (3/8" thick)	Poly (3/8" thick)
Frame Construction:	7-gauge (3/16" Steel)	7-gauge (3/16" Steel)
Rear Wheels (diameter x width):	14" x 5"	14" x 5"
Drive Wheel (diameter x width):	12" x 4"	12" x 4"
Size (L x W x H):	69" x 36" x 56"	69" x 36" x 56"
Weight:	1,230 pounds	1,230 pounds
Weight (w / batteries):	1,950 pounds	1,950 pounds

BRUSH SYSTEM:

Brush Down Pressure	0-350 pounds	0-350 pounds
Brush Pressure Settings	(5) w / auto adjust	(5) w / auto adjust
Brush /Pad Size:	34D: (2) 17" 40D: (2) 20"	34C: (2) 32" x 7" 40C: (2) 38" x 7" 46C: (2) 44" x 7"
Brush Speed	270-rpm	270-rpm
Motor Power:	(2) 1.5 hp	(2) 1.5 hp

BATTERY SYSTEM:

Battery AH Rating (standard):	(Qty 6) 325 AH	(Qty 6) 325 AH
Battery AH Rating (optional):	(Qty 6) 395 AH	(Qty 6) 395 AH
Battery AH Rating (industrial battery):	(Qty 1) 440 AH	(Qty 1) 440 AH
Battery Run Time:	Up to 6 hours	Up to 6 hours
Charger (110-v / 60 Hz / 24-volt):	36-v / 36 amp	36-v / 36 amp

SOLUTION SYSTEM:

Solution Tank Capacity:	68-gallons	68-gallons
Solution Flow Rate:	0-1.5 gpm	0-1.5 gpm
Solution Filter:	Inline Stainless	Inline Stainless

RECOVERY SYSTEM:

Recovery Tank Capacity:	68-gallons	68-gallons
Vacuum Power:	1.6 hp	1.6 hp
Vacuum (lift / airflow):	68" / 140 cfm	68" / 140 cfm
Demisting Chamber:	2.5 gallons	2.5 gallons

DRIVE SYSTEM:

Power:	3.0 hp, sealed	3.0 hp, sealed
Type:	All Gear	All Gear
Speed Control:	0-5 mph	0-5 mph

GENERAL:

Sound Levels:	71 dBA	71 dBA
Side Broom Path:	45"	45"
Cleaning Width:	34D: 34"/36,720 sq. ft./hr. 40D: 40"/34,200 sq. ft./hr.	34D: 34"/36,720 sq. ft./hr. 40D: 40"/34,200 sq. ft./hr.

RPS CORPORATION

P.O. Box 368
Racine, WI 53401
Phone: (800)634-4060
Fax: (866)901-3335

© RPS Corporation 2008.
All Rights Reserved.

Since our policy is one of constant improvement,
all specifications are subject to change without notice.

AUTHORIZED DISTRIBUTOR